

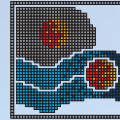

**INTERPUMP
GROUP**



Pratissoli

Pumps for an aggressive environment
Pompe in acciaio inox per ambienti aggressivi

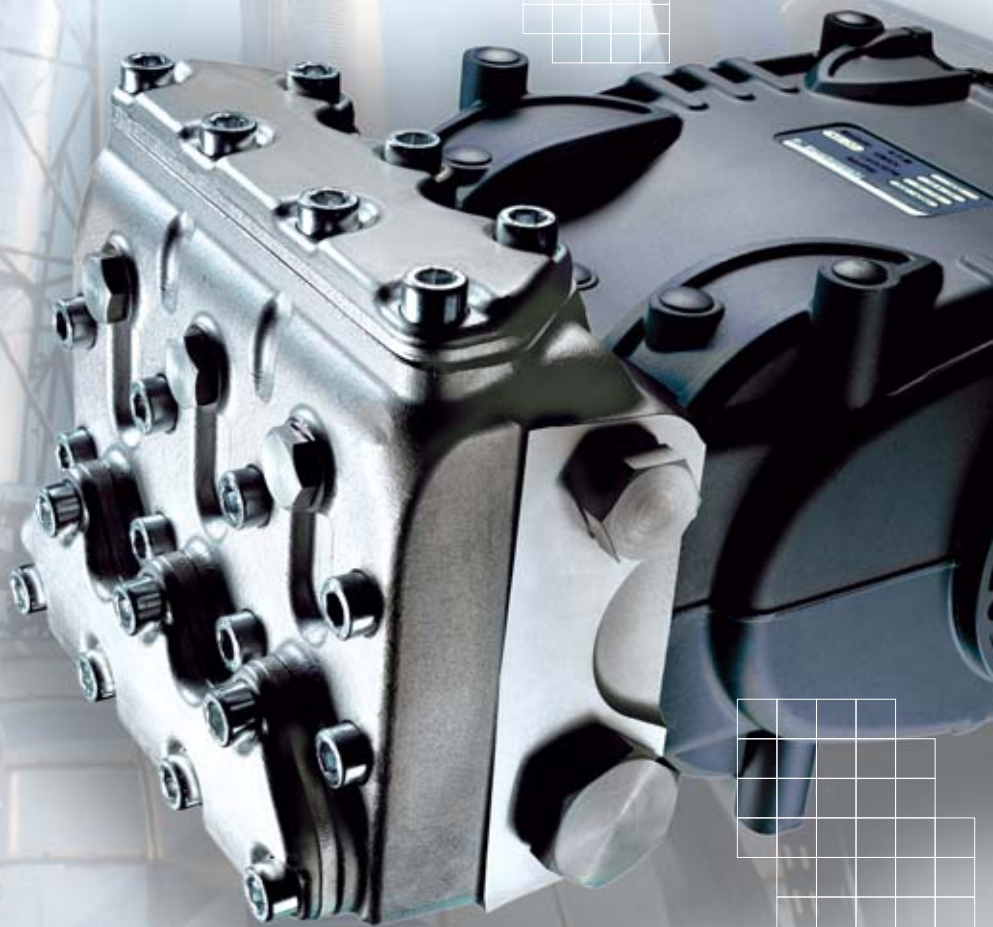

INTERPUMP GROUP

The synthesis of experience

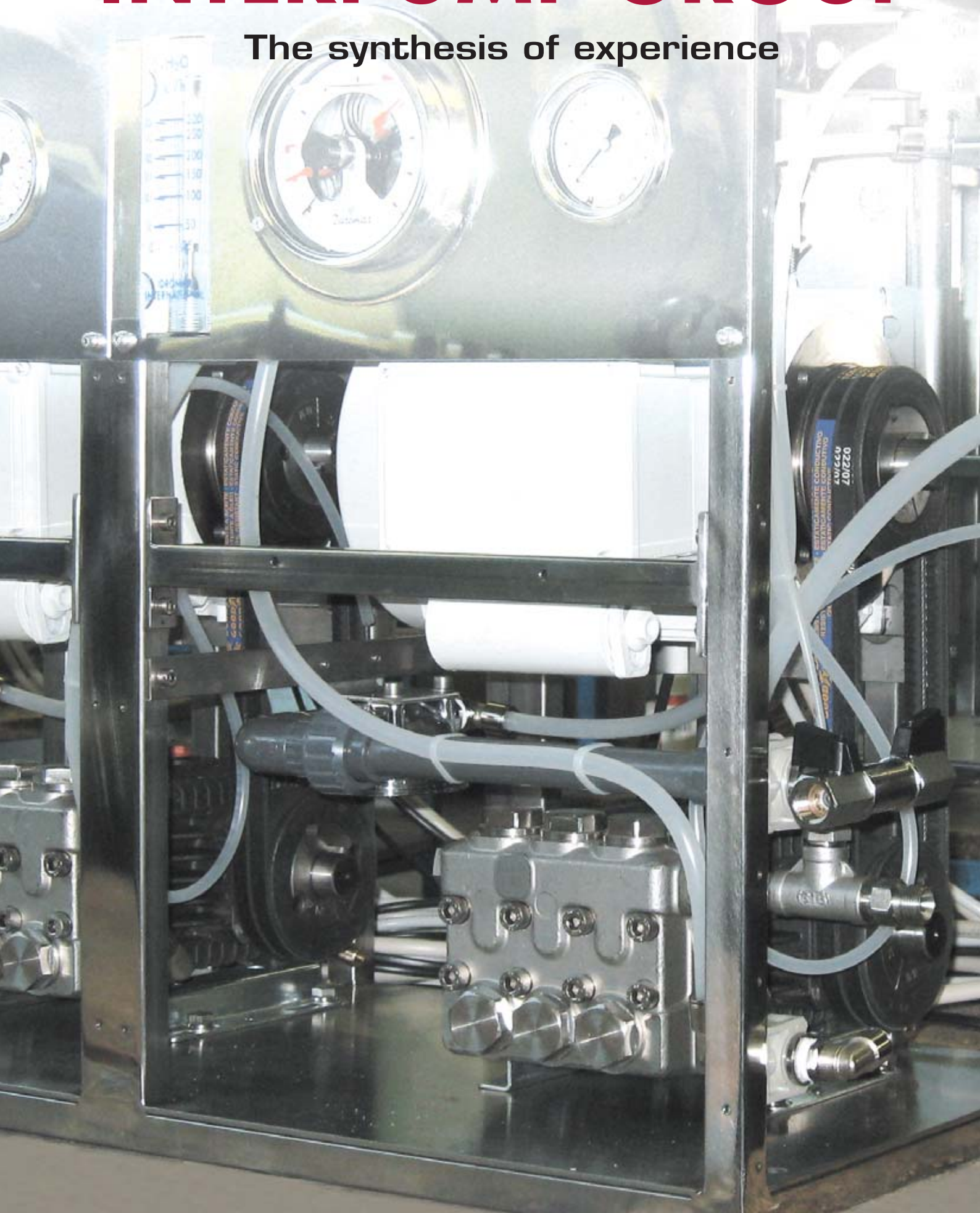

From the largest Manufacturer in the World, Proven Plunger Pumps Designed for the most Demanding Industrial Applications:



Desalination

Oil & Gas

Processing

- Reverse Osmosis
- Waste water injection
- Blow out preventer charging
- Hydrostatic testing
- Chemical injection
- Deionized water
- Turbine misting-cooling
- Glycol injection
- Methanol injection
- Power generation
- Pharmaceutics

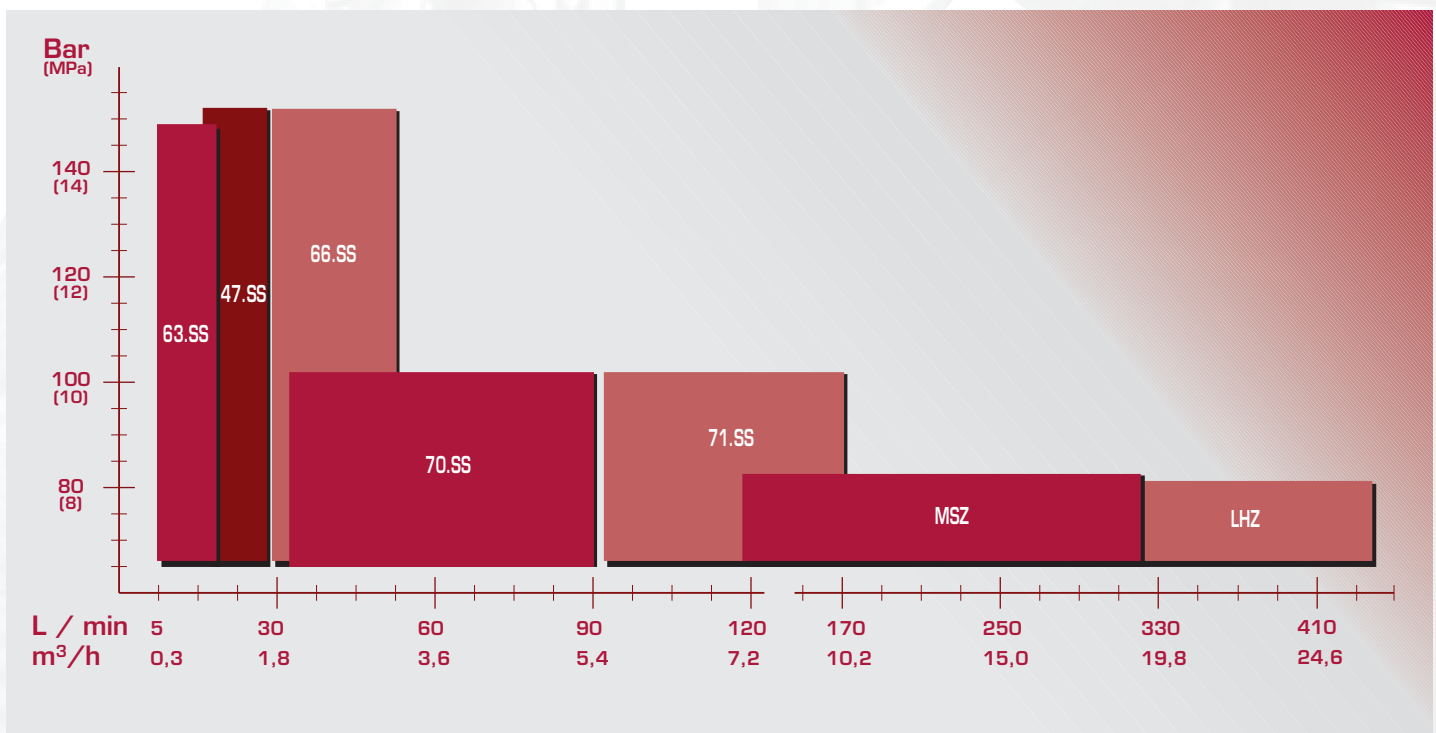

63.SS series

stainless steel

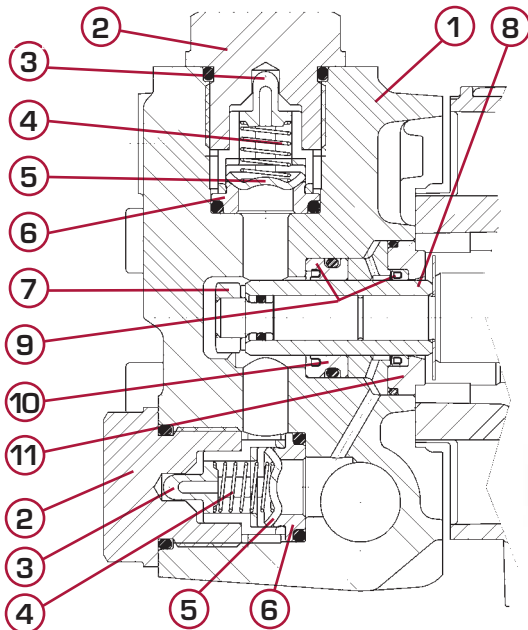

Materiali a contatto con il fluido - Material quality (wetted parts)

Pos.	Descrizione - Description	Materiale - Material
1	Testata - Manifold	Acciaio inox AISI 316L - AISI 316L stainless steel
2	Tappo valvola - Valve cap	Acciaio inox AISI 316L - AISI 316L stainless steel
3	Guida valvola - Valve guide	Poliammide (PA11) - Polyamide (PA11)
4	Molla valvola - Valve spring	Acciaio inox AISI 316L - AISI 316L stainless steel
5	Valvola - Valve	Acciaio inox AISI 316L - AISI 316L stainless steel
6	Sede valvola - Valve seat	Acciaio inox AISI 316L - AISI 316L stainless steel
7	Dado fissaggio pistone - Plunger nut	Acciaio inox AISI 316L - AISI 316L stainless steel
8	Pistone - Plunger	Ceramica integrale - Solid ceramic
9	Anelli di tenuta - Seal rings	Politetrafluoroetilene (PTFE) - Polytetrafluoroethylene (PTFE)
10	Anello intermedio - Intermediate ring	Acciaio inox AISI 316L - AISI 316L stainless steel
11	Anello di fondo - Retainer	Acciaio inox AISI 316L - AISI 316L stainless steel
	Elastometri a contatto con il fluido - Wetted elastomers	NBR & EPDM

Tabella prestazioni - Performances chart:

Tipo pompa Pump type	Portata Volume		Pressione Pressure			g/min r.p.m.	Potenza Power		Alesaggio per corsa Bore x stroke mm	Dimensioni mm Dimensions mm
	l/min	US Gpm	bar	MPa	p.s.i.		hp	kW		
SSE1505	5	1.32	150	15	2175	1450	2	1,43	Ø15 X 6,5	213,5x211x119,5
SSE 1507	7	1.85	150	15	2175	1450	3	2,20	Ø15 X 10	213,5x211x119,5
SSE 1509	9	2.38	150	15	2175	1450	3,5	2,57	Ø15 X 12	213,5x211x119,5
SSU 1509	9	2.38	150	15	2175	1750	3,5	2,57	Ø15 X 10	213,5x211x119,5
SSE 1411	11	2.90	140	14	2030	1450	4	2,94	Ø18 X 10	213,5x211x119,5
SSU 1511	11	2.90	150	15	2175	1750	4,5	3,30	Ø15 X 12	213,5x211x119,5
SSE 1413	13	3.43	140	14	2030	1450	4,8	3,52	Ø18 X 12	213,5x211x119,5
SSU 1413	13	3.43	138	13,8	2000	1750	4,7	3,45	Ø18 X 10	213,5x211x119,5
SSE 1414	14	3.69	140	14	2030	1450	5,1	3,75	Ø18 X 13	213,5x211x119,5
SSU 1415	15,2	4.02	138	13,8	2000	1750	5,5	4,04	Ø18 X 12	213,5x211x119,5

Portate teoriche con rendimento volumetrico 100% - Volumes are theoretical with 100% volumetric efficiency.

63.SS series

stainless steel



Descrizione - Description

- Pompa volumetrica alternativa a tre pistoni tuffanti orizzontali, realizzata espressamente per applicazioni nell'industria alimentare, chimica, farmaceutica, per osmosi inversa, purificazione, iniezione, processo.
- Tenute alta pressione speciali energizzate.
- Parti a contatto con il fluido in acciaio inox (vedi tabella materiali per dettagli).
- Pistoni in ceramica integrale.
- Lubrificazione a sbattimento.
- *Triplex positive displacement reciprocating plunger pump, expressly designed for heavy duty applications in the food, chemical and pharmaceutical industries, such as reverse osmosis, purification, injection and processing.*
- *Energized special pressure packings.*
- *Wetted parts in stainless steel (see material quality chart).*
- *Solid ceramic plungers.*
- *Oil-bath mechanical parts with splash lubrication.*

Specifiche tecniche - Specifications

Velocità minima (Consentite velocità di rotazione inferiori, previo verifica applicazioni) <i>Min. speed (Slower speed allowed after technical approval only)</i>	500 r.p.m.
Battente max. <i>Max. inlet pressure</i>	8 bar (116 p.s.i.)
Capacità olio <i>Oil capacity</i>	0,4 l. (13.5 fl.oz.U.S.)
Inlet	n.2 x G 1/2" BSP
Outlet	n.2 x G 3/8" BSP
Max inlet temp: Pistone / Plunger Ø 15 Pistone / Plunger Ø 18	60° C (140 °F) 85° C (185 °F)
Peso / Weight	9 kg (20 lbs)

Giunti - Flange vedi pag.20
Flex. couplings - Flanges see page 20

Grafico potenza/pressioni - Performance curves based on operating pressure

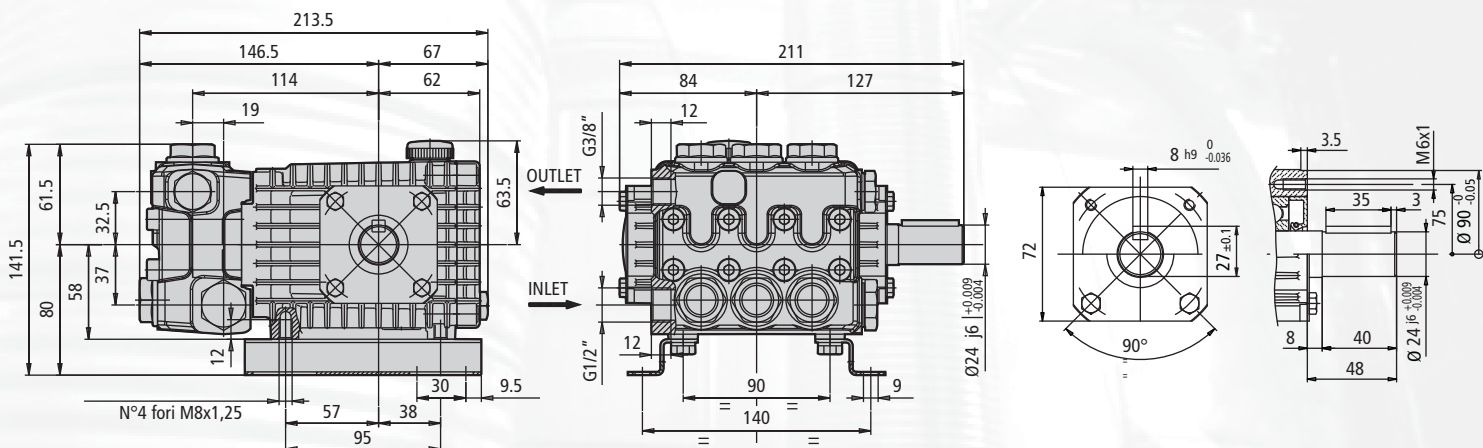
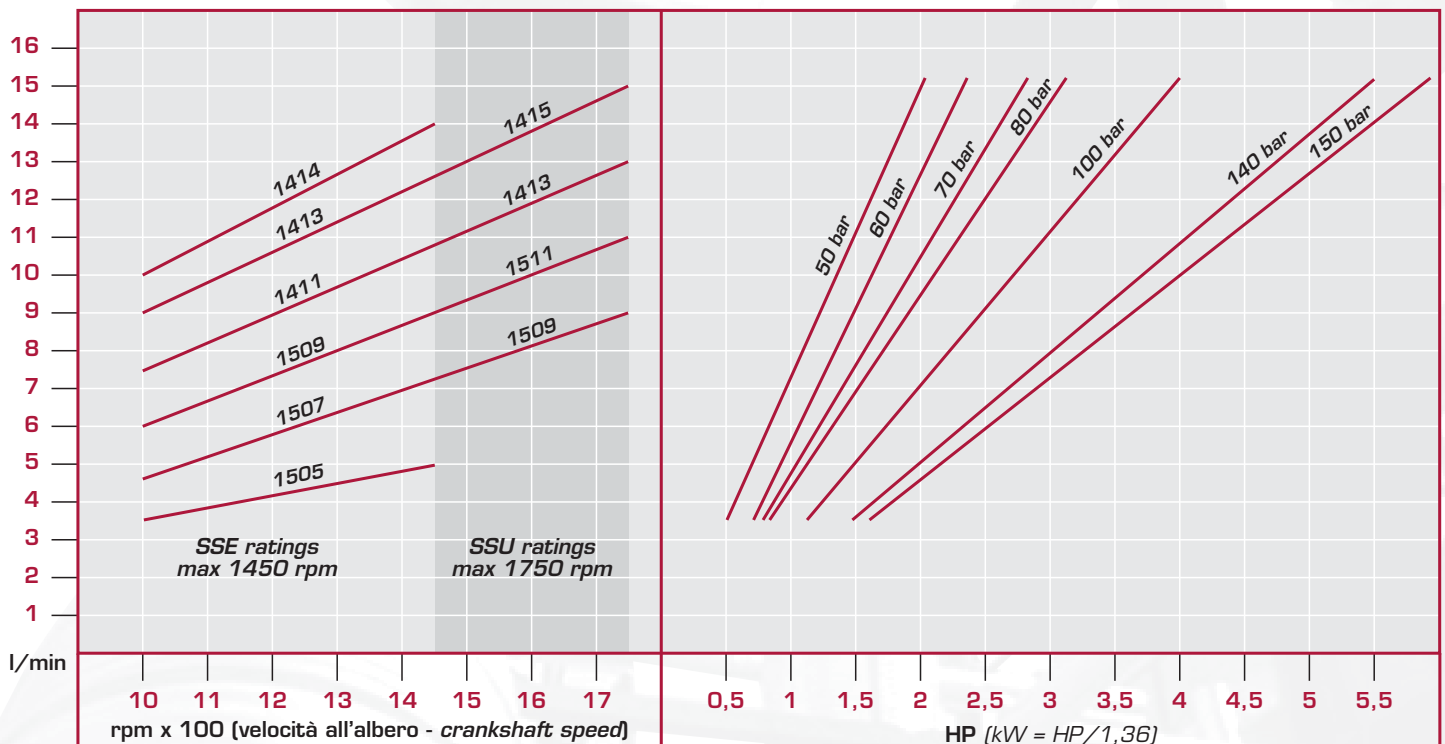

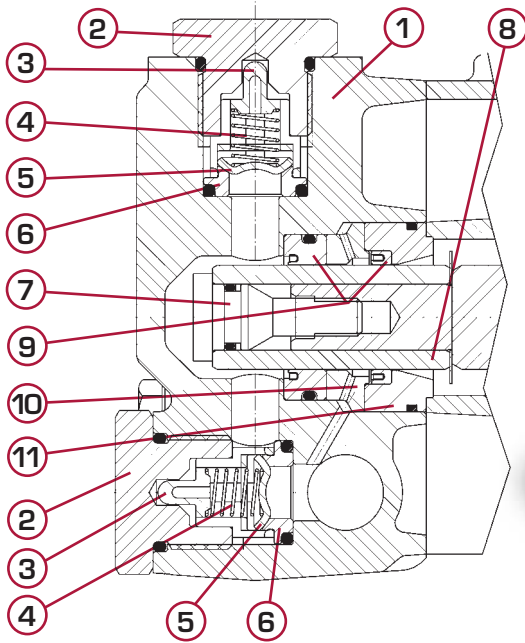

Materiali a contatto con il fluido - Material quality (wetted parts)

Pos.	Descrizione - Description	Materiale - Material
1	Testata - Manifold	Acciaio inox AISI 316L - AISI 316L stainless steel
2	Tappo valvola - Valve cap	Acciaio inox AISI 316L - AISI 316L stainless steel
3	Guida valvola - Valve guide	Poliammide (PA11) - Polyamide (PA11)
4	Molla valvola - Valve spring	Acciaio inox AISI 316L - AISI 316L stainless steel
5	Valvola - Valve	Acciaio inox AISI 316L - AISI 316L stainless steel
6	Sede valvola - Valve seat	Acciaio inox AISI 316L - AISI 316L stainless steel
7	Vite fissaggio pistone - Plunger screw	Acciaio inox AISI 316L - AISI 316L stainless steel
8	Pistone - Plunger	Ceramica integrale - Solid ceramic
9	Anelli di tenuta - Seal rings	Politetrafluoroetilene (PTFE) - Polytetrafluoroethylene (PTFE)
10	Anello intermedio - Intermediate ring	Acciaio inox AISI 316L - AISI 316L stainless steel
11	Anello di fondo - Retainer	Acciaio inox AISI 316L - AISI 316L stainless steel
	Elastometri a contatto con il fluido - Wetted elastomers	NBR & EPDM

Tabella prestazioni - Performances chart:

Tipo pompa Pump type	Portata Volume		Pressione Pressure			g/min r.p.m.	Potenza Power		Alesaggio per corsa Bore x stroke mm	Dimensioni mm Dimensions mm
	l/min	US Gpm	bar	MPa	p.s.i.		hp	kW		
SSE 1513	13	3.43	150	15	2175	1450	5	3,67	Ø20 X 10	315,5x234x146
SSE 1515	15	3.96	150	15	2175	1450	5,5	4,04	Ø20 X 12	315,5x234x146
SSU 1515	15	3.96	150	15	2175	1750	5,5	4,04	Ø20 X 10	315,5x234x146
SSE 1518	18	4.75	150	15	2175	1450	7	5,14	Ø22 X 12	315,5x234x146
SSU 1518	18	4.750	150	15	2175	1750	7	5,14	Ø20 X 12	315,5x234x146
SSE1521	21	5.55	150	15	2175	1450	7,5	5,51	Ø20 X 16	315,5x234x146
SSU 1521	21	5.55	150	15	2175	1750	7,5	5,51	Ø22 X 12	315,5x234x146

Portate teoriche con rendimento volumetrico 100% - Volumes are theoretical with 100% volumetric efficiency.

47.SS series

stainless steel



Descrizione - Description

- Pompa volumetrica alternativa a tre pistoni tuffanti orizzontali, realizzata espressamente per applicazioni nell'industria alimentare, chimica, farmaceutica, per osmosi inversa, purificazione, iniezione, processo.
- Tenute alta pressione speciali energizzate.
- Parti a contatto con il fluido in acciaio inox (vedi tabella materiali per dettagli).
- Pistoni in ceramica integrale.
- Lubrificazione a sbattimento.
- *Triplex positive displacement reciprocating plunger pump, expressly designed for heavy duty applications in the food, chemical and pharmaceutical industries, such as reverse osmosis, purification, injection and processing.*
- *Energized special pressure packings.*
- *Wetted parts in stainless steel (see material quality chart).*
- *Solid ceramic plungers.*
- *Oil-bath mechanical parts with splash lubrication.*

Specifiche tecniche - Specifications

Velocità minima (Consentite velocità di rotazione inferiori, previo verifica applicazioni) <i>Min. speed (Slower speed allowed after technical approval only)</i>	500 r.p.m.
Battente max. <i>Max. inlet pressure</i>	8 bar (116 p.s.i.)
Capacità olio <i>Oil capacity</i>	1,2 l. (40.5 fl.oz.U.S.)
Inlet	n.2 x G 1/2" BSP
Outlet	n.2 x G 3/8" BSP
Max inlet temp: Pistone / Plunger Ø 20 Pistone / Plunger Ø 22	60° C (140 °F) 85° C (185 °F)
Peso / Weight	14,5 kg (32 lbs)

Giunti - Flange vedi pag.20
Flex. couplings - Flanges see page 20

Grafico potenza/pressioni - Performance curves based on operating pressure

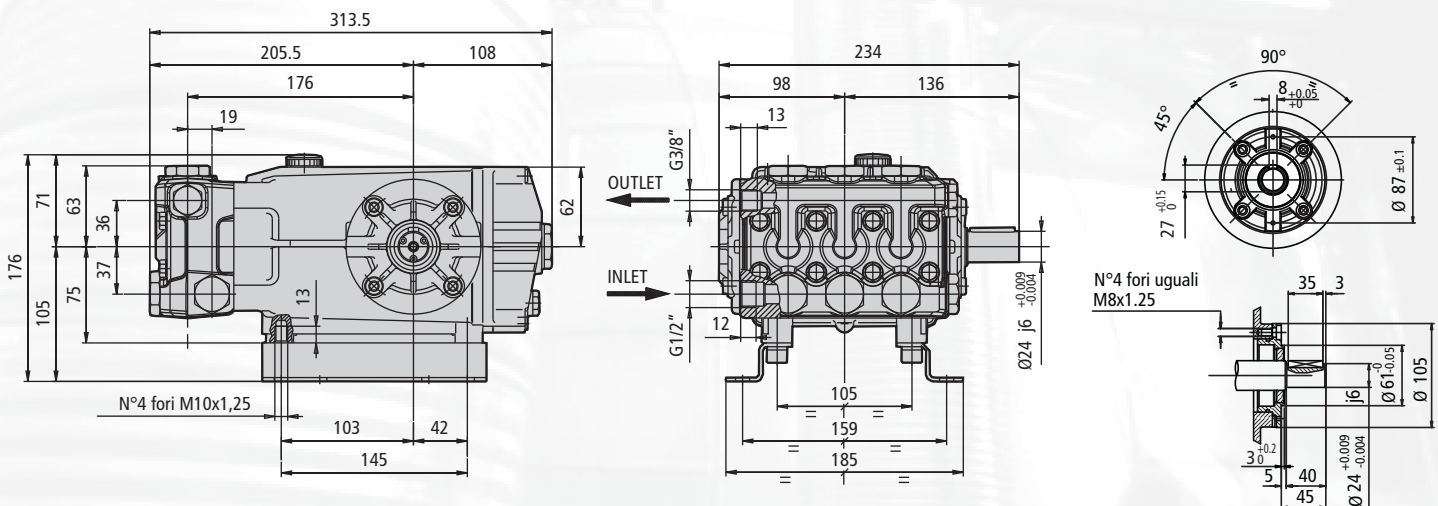
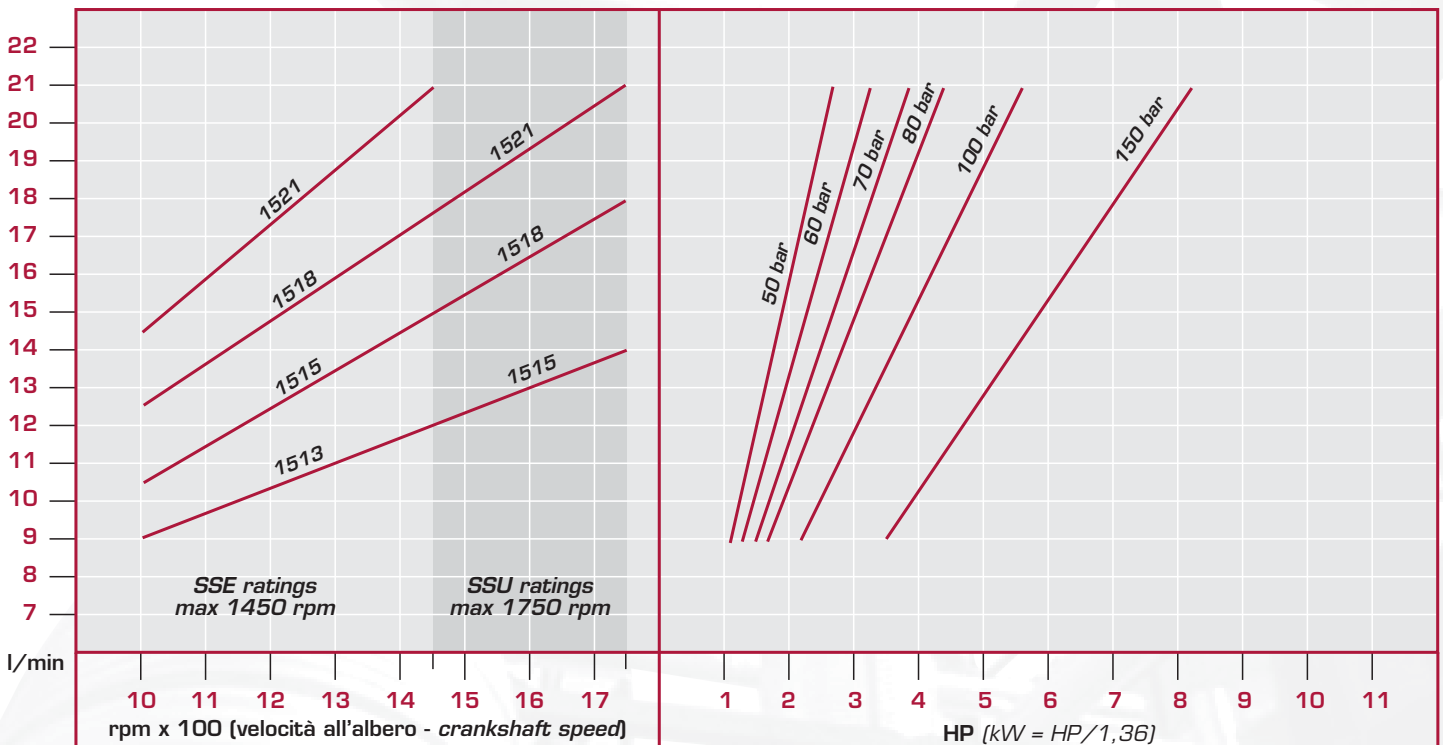

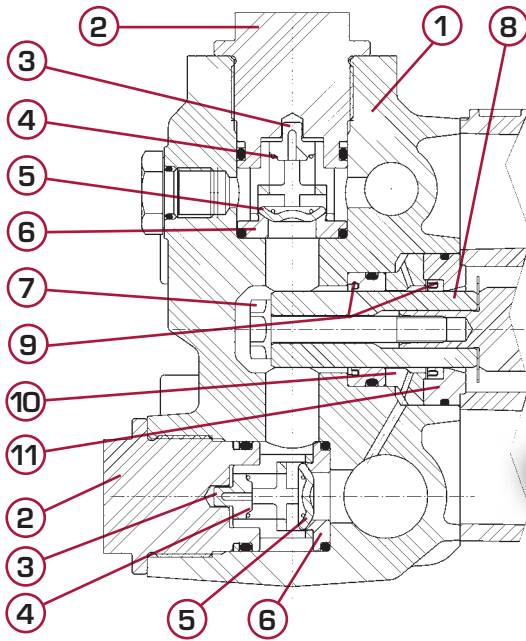

Materiali a contatto con il fluido - Material quality (wetted parts)

Pos.	Descrizione - Description	Materiale - Material
1	Testata - Manifold	Acciaio inox AISI 316L - AISI 316L stainless steel
2	Tappo valvola - Valve cap	Acciaio inox AISI 316L - AISI 316L stainless steel
3	Guida valvola - Valve guide	Poliammide (PA11) - Polyamide (PA11)
4	Molla valvola - Valve spring	Acciaio inox AISI 302 - AISI 302 stainless steel
5	Valvola - Valve	Acciaio inox AISI 316L - AISI 316L stainless steel
6	Sede valvola - Valve seat	Acciaio inox AISI 316L - AISI 316L stainless steel
7	Vite fissaggio pistone - Plunger screw	Acciaio inox AISI 316L - AISI 316L stainless steel
8	Pistone - Plunger	Ceramica integrale - Solid ceramic
9	Anelli di tenuta - Seal rings	Politetrafluoroetilene (PTFE) - Polytetrafluoroethylene (PTFE)
10	Anello intermedio - Intermediate ring	Acciaio inox AISI 316L - AISI 316L stainless steel
11	Anello di fondo - Retainer	Acciaio inox AISI 316L - AISI 316L stainless steel
	Elastometri a contatto con il fluido - Wetted elastomers	NBR & EPDM

Tabella prestazioni - Performances chart:

Tipo pompa Pump type	Portata Volume		Pressione Pressure			g/min r.p.m.	Potenza Power		Alesaggio per corsa Bore x stroke mm	Dimensioni mm Dimensions mm
	l/min	US Gpm	bar	MPa	p.s.i.		hp	kW		
SSE 1525	25	6.60	150	15	2175	1450	9,7	7,13	Ø20 X 19	340,5x248,5x159,5
SSE 1530	30	7.92	150	15	2175	1450	11,7	8,60	Ø22 X 19	340,5x248,5x159,5
SSU 1530	30	7.92	150	15	2175	1750	11,7	8,60	Ø20 X 19	340,5x248,5x159,5
SSE 1535	35	9.25	150	15	2175	1450	13,6	10	Ø22 X 21	340,5x248,5x159,5
SSU 1535	35	9.25	150	15	2175	1750	13,6	10	Ø20 X 21	340,5x248,5x159,5
SSU 1540	40	10.56	150	15	2175	1750	15,6	11,47	Ø22 X 21	340,5x248,5x159,5
SSE 1541	41	10.83	150	15	2175	1450	16	11,76	Ø24 X 21	340,5x248,5x159,5
SSU 1550	50	13.20	150	15	2175	1750	19,5	14,32	Ø24 X 21	340,5x248,5x159,5

Portate teoriche con rendimento volumetrico 100% - Volumes are theoretical with 100% volumetric efficiency.

66.SS series

stainless steel



Descrizione - Description

- Pompa volumetrica alternativa a tre pistoni tuffanti orizzontali, realizzata espressamente per applicazioni nell'industria alimentare, chimica, farmaceutica, per osmosi inversa, purificazione, iniezione, processo.
- Tenute alta pressione speciali energizzate.
- Parti a contatto con il fluido in acciaio inox (vedi tabella materiali per dettagli).
- Pistoni in ceramica integrale.
- Lubrificazione a sbattimento.
- *Triplex positive displacement reciprocating plunger pump, expressly designed for heavy duty applications in the food, chemical and pharmaceutical industries, such as reverse osmosis, purification, injection and processing.*
- *Energized special pressure packings.*
- *Wetted parts in stainless steel (see material quality chart).*
- *Solid ceramic plungers.*
- *Oil-bath mechanical parts with splash lubrication.*

Specifiche tecniche - Specifications

Velocità minima (Consentite velocità di rotazione inferiori, previo verifica applicazioni) <i>Min. speed (Slower speed allowed after technical approval only)</i>	500 r.p.m.
Battente max. <i>Max. inlet pressure</i>	8 bar (116 p.s.i.)
Capacità olio <i>Oil capacity</i>	1,2 l. (40.5 fl.oz.U.S.)
Inlet	n.2 x G 3/4" BSP
Outlet	n.2 x G 3/8" BSP
Max inlet temp.	85° C (185 °F)
Peso / Weight	21 kg (46 lbs)

Giunti - Flange vedi pag.20
Flex. couplings - Flanges see page 20

Grafico potenza/pressioni - Performance curves based on operating pressure

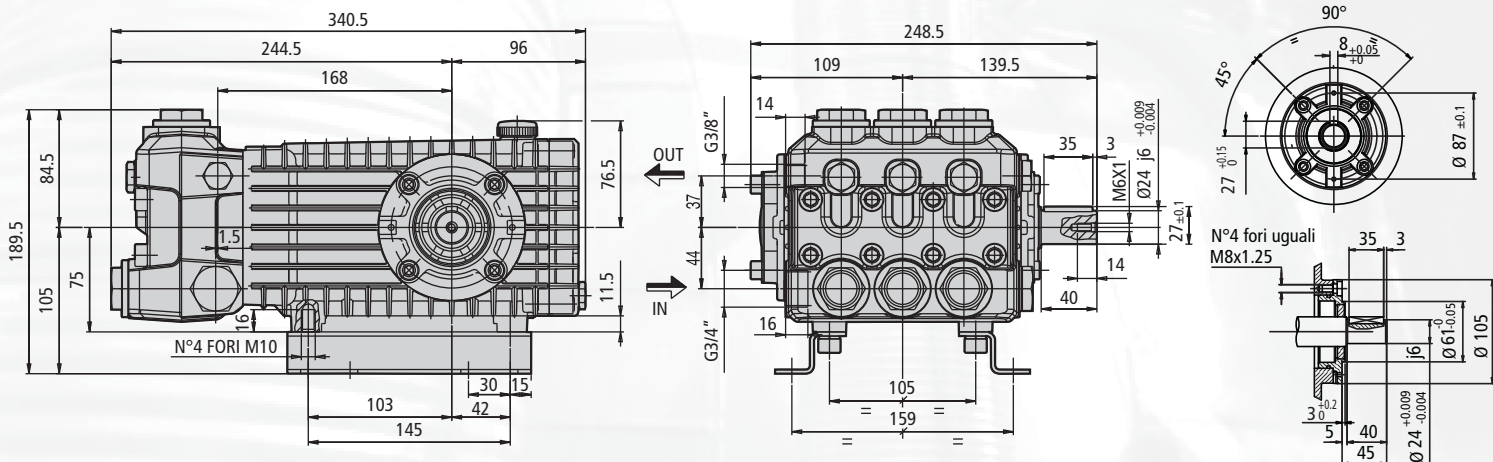
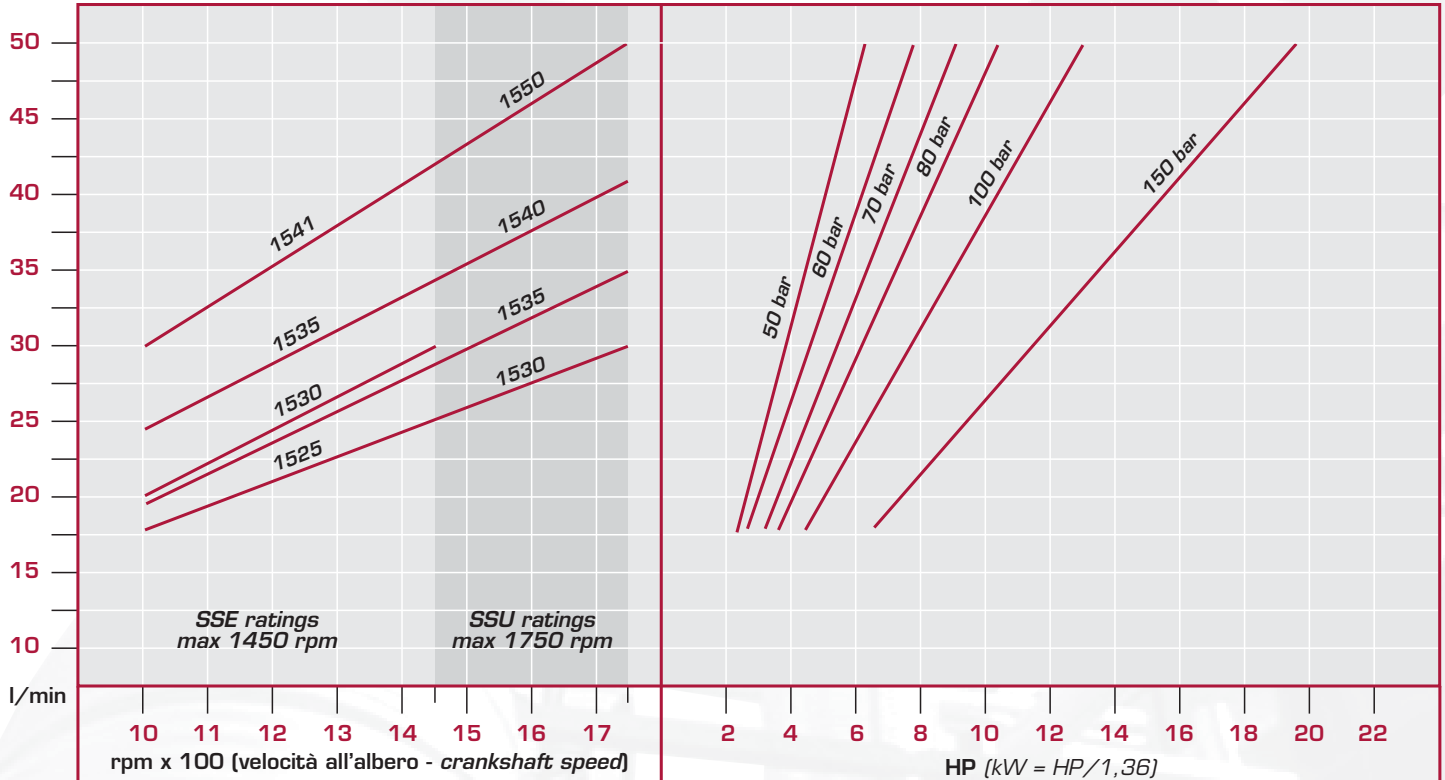

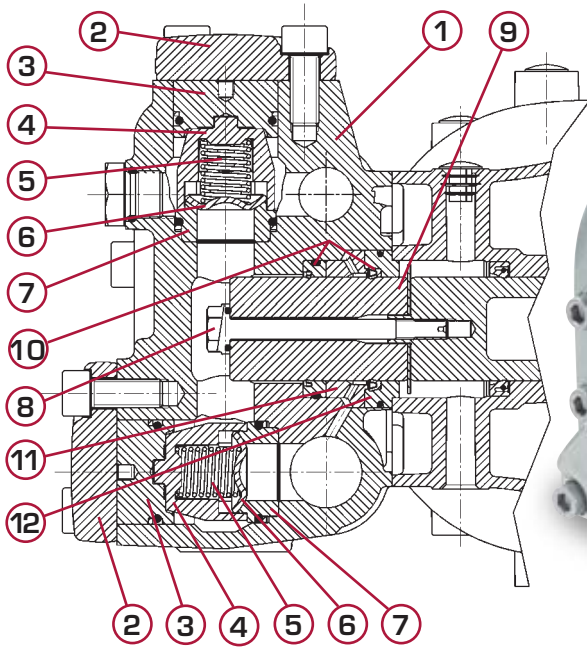

Materiali a contatto con il fluido - Material quality (wetted parts)

Pos.	Descrizione - Description	Materiale - Material
1	Testata - Manifold	Acciaio inox AISI 316L - AISI 316L stainless steel
2	Coperchio valvole - Valve cover	Acciaio inox AISI 316L - AISI 316L stainless steel
3	Tappo valvola - Valve cap	Acciaio inox AISI 316L - AISI 316L stainless steel
4	Guida valvola - Valve guide	Politiamide (PPA) - PPA polymer
5	Molla valvola - Valve spring	Acciaio inox AISI 302 - AISI 302 stainless steel
6	Valvola - Valve	Acciaio inox AISI 316L - AISI 316L stainless steel
7	Sede valvola - Valve seat	Acciaio inox AISI 316L - AISI 316L stainless steel
8	Vite fissaggio pistone - Plunger screw	Acciaio inox AISI 316L - AISI 316L stainless steel
9	Pistone - Plunger	Ceramica integrale - Solid ceramic
10	Anelli di tenuta - Seal rings	Politetrafluoroetilene (PTFE) - Polytetrafluoroethylene (PTFE)
11	Anello intermedio - Intermediate ring	Acciaio inox AISI 316L - AISI 316L stainless steel
12	Anello di fondo - Retainer	Acciaio inox AISI 316L - AISI 316L stainless steel
	Elastometri a contatto con il fluido - Wetted elastomers	NBR & EPDM

Tabella prestazioni - Performances chart:

Tipo pompa Pump type	Portata Volume		Pressione Pressure			g/min r.p.m.	Potenza Power		Alesaggio per corsa Bore x stroke mm	Dimensioni mm Dimensions mm
	l/min	US Gpm	bar	MPa	p.s.i.		hp	kW		
SS70 91	35	9.30	100	10	1450	500	9,1	6,7	Ø36 X 23	387x340,5x196
	53	14.00	100	10	1450	750	13,8	10,1	Ø36 X 23	387x340,5x196
	70	18.50	100	10	1450	1000	18,2	13,4	Ø36 X 23	387x340,5x196
	84	22.20	100	10	1450	1200	21,8	16,1	Ø36 X 23	387x340,5x196
	91	24.00	100	10	1450	1300	23,6	17,4	Ø36 X 23	387x340,5x196

Portate teoriche con rendimento volumetrico 100% - Volumes are theoretical with 100% volumetric efficiency.

Descrizione - Description

- Pompa volumetrica alternativa a tre pistoni tuffanti orizzontali, realizzata espressamente per applicazioni nell'industria alimentare, chimica, farmaceutica, per osmosi inversa, purificazione, iniezione, processo.
- Tenute alta pressione speciali energizzate.
- Parti a contatto con il fluido in acciaio inox (vedi tabella materiali per dettagli).
- Pistoni in ceramica integrale.
- Carter ad alta dissipazione di calore (brevettato).
- Lubrificazione a sbattimento.
- *Triplex positive displacement reciprocating plunger pump, expressly designed for heavy duty applications in the food, chemical, pharmaceutical industries, such a reverse osmosis, purification, injection and processing.*
- *Energized special pressure packing.*
- *Wetted parts in stainless steel (see material quality chart).*
- *Solid ceramic plungers.*
- *High heat dissipation crankcase (patented).*
- *Oil-bath mechanical parts with splash lubrication.*

Specifiche tecniche - Specifications

Velocità minima (Consentite velocità di rotazione inferiori, previo verifica applicazioni) <i>Min. speed (Slower speed allowed after technical approval only)</i>	500 r.p.m.
Battente max. <i>Max. inlet pressure</i>	3 bar (43,5 p.s.i.)
Capacità olio <i>Oil capacity</i>	3 l. (101.4 fl.oz.U.S.)
Inlet	n.2 x G 1" BSP
Outlet	n.2 x G 1/2" BSP
Max inlet temp.	85° C (185 °F)
Peso / Weight	36 kg (79 lbs)

Giunti - Flange vedi pag.20
Flex. couplings - Flanges see page 20

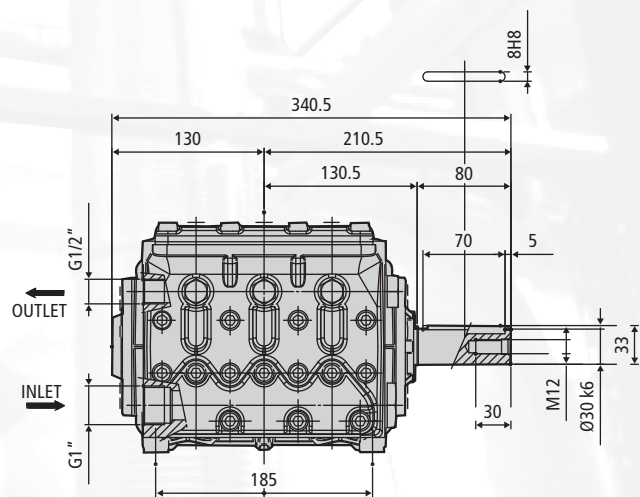
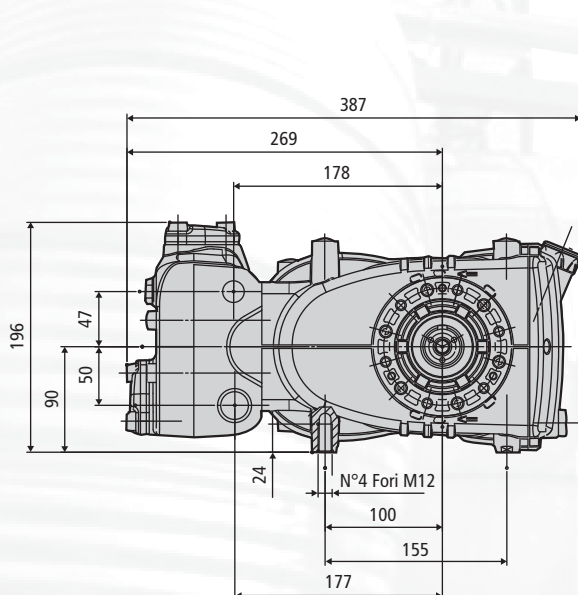
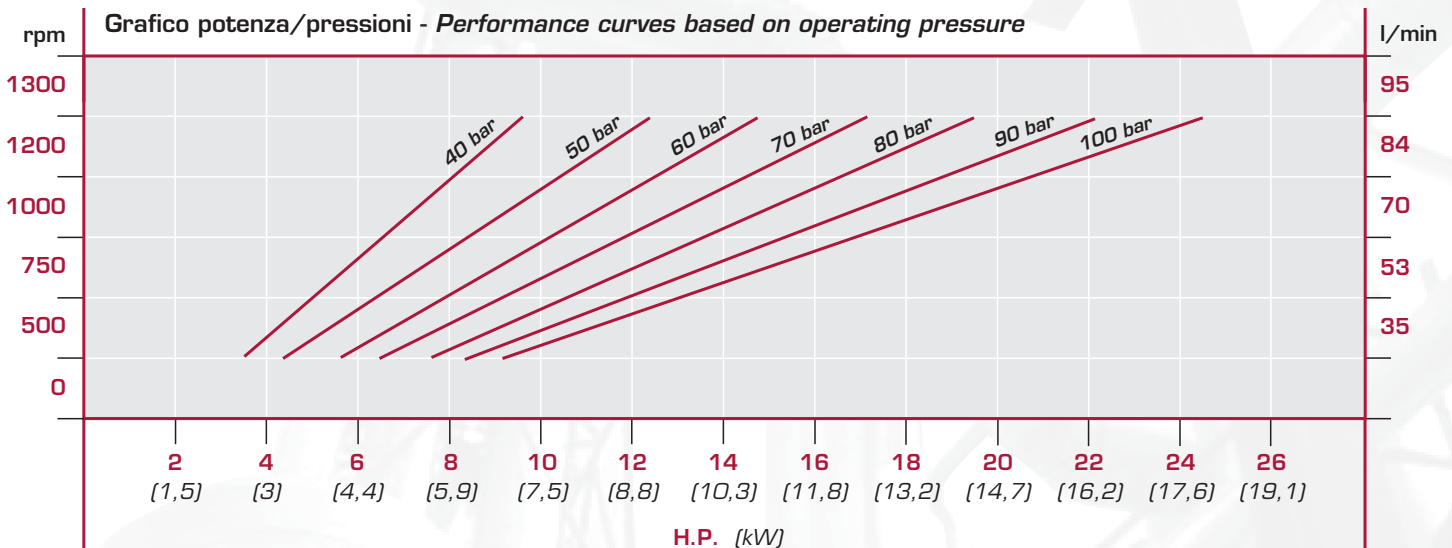

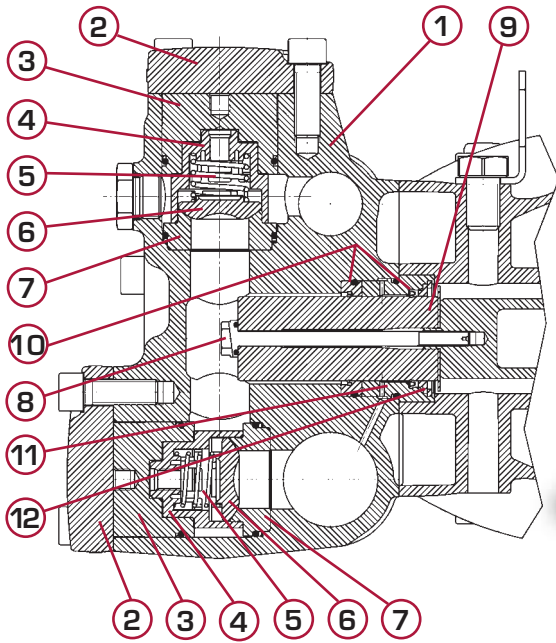

Materiali a contatto con il fluido - Material quality (wetted parts)

Pos.	Descrizione - Description	Materiale - Material
1	Testata - Manifold	Acciaio inox AISI 316L - AISI 316L stainless steel
2	Coperchio valvole - Valve cover	Acciaio inox AISI 316L - AISI 316L stainless steel
3	Tappo valvola - Valve cap	Acciaio inox AISI 316L - AISI 316L stainless steel
4	Guida valvola - Valve guide	Politiamide (PPA) - PPA polymer
5	Molla valvola - Valve spring	Acciaio inox AISI 302 - AISI 302 stainless steel
6	Valvola - Valve	Acciaio inox AISI 316L - AISI 316L stainless steel
7	Sede valvola - Valve seat	Acciaio inox AISI 316L - AISI 316L stainless steel
8	Vite fissaggio pistone - Plunger screw	Acciaio inox AISI 316L - AISI 316L stainless steel
9	Pistone - Plunger	Ceramica integrale - Solid ceramic
10	Anelli di tenuta - Seal rings	Politetrafluoroetilene (PTFE) - Polytetrafluoroethylene (PTFE)
11	Anello intermedio - Intermediate ring	Acciaio inox AISI 316L - AISI 316L stainless steel
12	Anello di fondo - Retainer	Acciaio inox AISI 316L - AISI 316L stainless steel
	Elastometri a contatto con il fluido - Wetted elastomers	NBR & EPDM

Tabella prestazioni - Performances chart:

Tipo pompa Pump type	Portata Volume		Pressione Pressure			g/min r.p.m.	Potenza Power		Alesaggio per corsa Bore x stroke mm	Dimensioni mm Dimensions mm
	l/min	US Gpm	bar	MPa	p.s.i.		hp	kW		
SS71 170	94	24.90	100	10	1450	500	24,5	18	Ø40 X 50	526x367x252,5
	113	29.90	100	10	1450	600	29,4	21,6	Ø40 X 50	526x367x252,5
	132	34.90	100	10	1450	700	34,3	25,2	Ø40 X 50	526x367x252,5
	150	39.60	100	10	1450	800	39	28,7	Ø40 X 50	526x367x252,5
	170	44.90	100	10	1450	900	44,2	32,5	Ø40 X 50	526x367x252,5

Portate teoriche con rendimento volumetrico 100% - Volumes are theoretical with 100% volumetric efficiency.

71.SS series

stainless steel



Descrizione - Description

- Pompa volumetrica alternativa a tre pistoni tuffanti orizzontali, realizzata espressamente per applicazioni nell'industria alimentare, chimica, farmaceutica, per osmosi inversa, purificazione, iniezione, processo.
- Tenute alta pressione speciali energizzate.
- Parti a contatto con il fluido in acciaio inox (vedi tabella materiali per dettagli).
- Pistoni in ceramica integrale.
- Carter ad alta dissipazione di calore (brevettato).
- Lubrificazione a sbattimento.
- *Triplex positive displacement reciprocating plunger pump, expressly designed for heavy duty applications in the food, chemical, pharmaceutical industries, such a reverse osmosis, purification, injection and processing.*
- *Energized special pressure packing.*
- *Wetted parts in stainless steel (see material quality chart).*
- *Solid ceramic plungers.*
- *High heat dissipation crankcase (patented).*
- *Oil-bath mechanical parts with splash lubrication.*

Specifiche tecniche - Specifications

Velocità minima (Consentite velocità di rotazione inferiori, previo verifica applicazioni) <i>Min. speed (Slower speed allowed after technical approval only)</i>	500 r.p.m.
Battente max. <i>Max. inlet pressure</i>	3 bar (43,5 p.s.i.)
Capacità olio <i>Oil capacity</i>	3,8 l. (128.5 fl.oz.U.S.)
Inlet	n.2 x 1" 1/2 BSP optional n.2 x 1"1/2 NPT
Outlet	n.2 x 1" BSP optional n.2 x 1" NPT
Max inlet temp.	85° C (185 °F)
Peso / Weight	70 kg (154 lbs)

Giunti - Flange vedi pag.20
Flex. couplings - Flanges see page 20

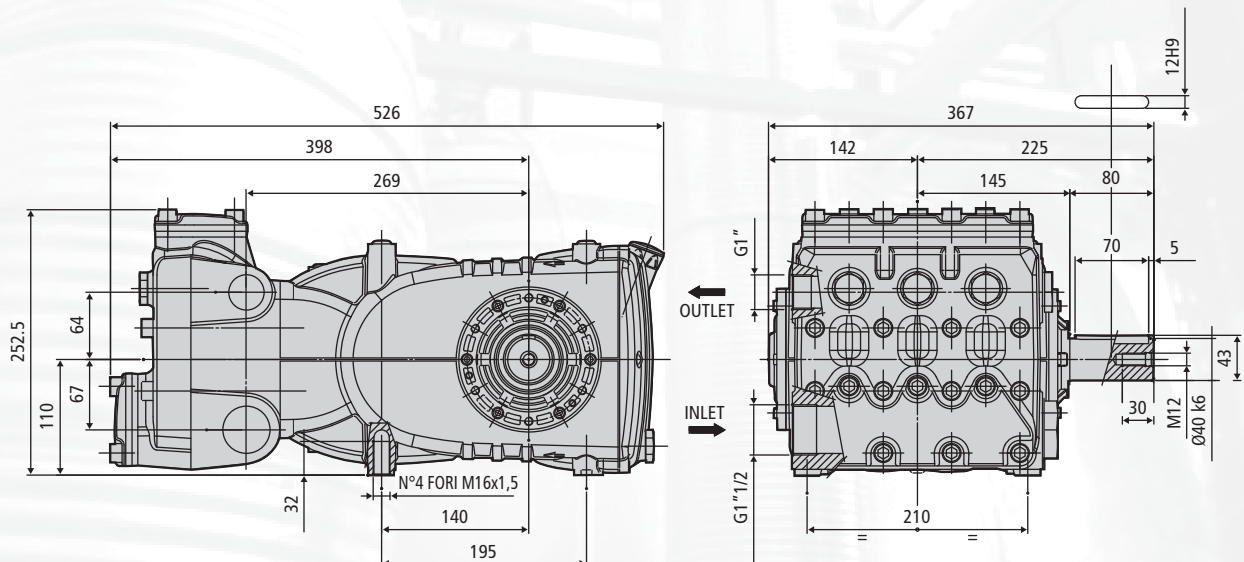
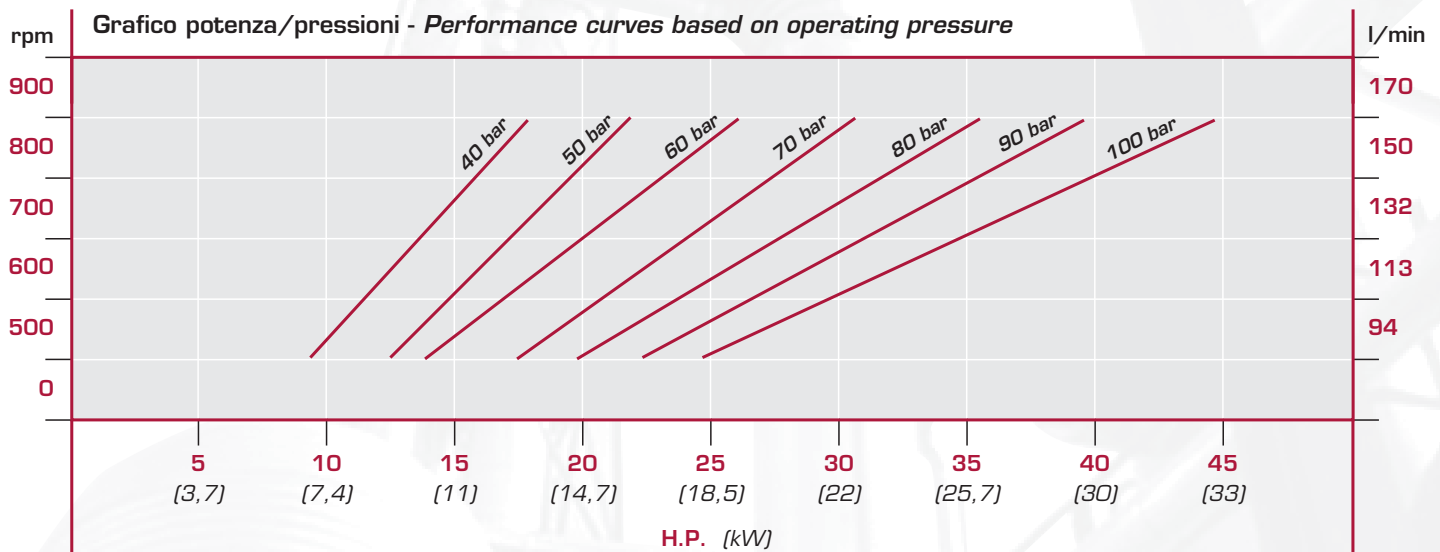

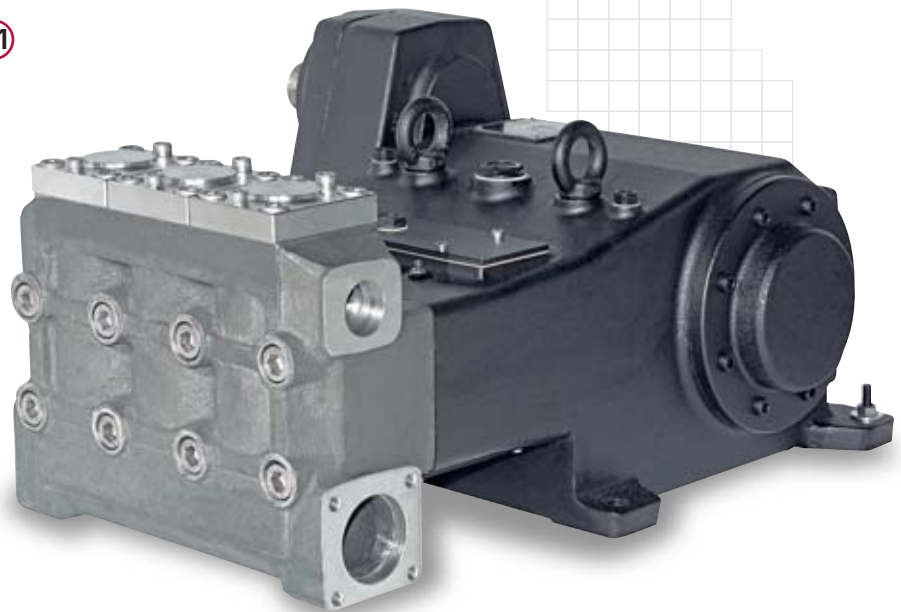
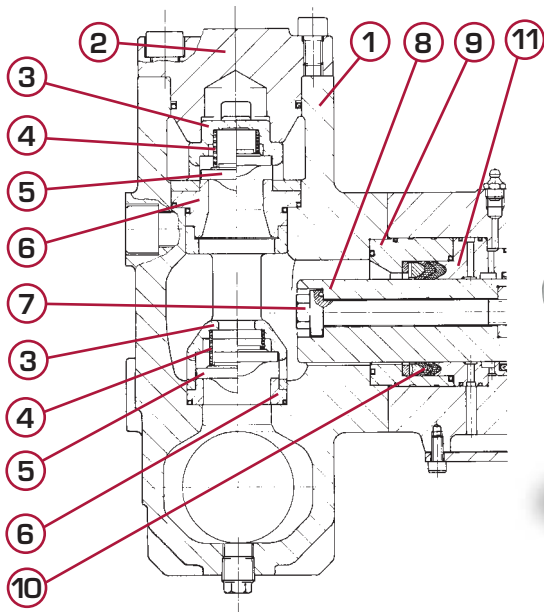
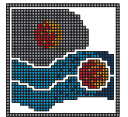

Materiali a contatto con il fluido - Material quality (wetted parts)

Pos.	Descrizione - Description	Materiale - Material
1	Testata - Manifold	Acciaio inox ASTM A890 gr.4 - ASTM A890 gr.4 s.s.
2	Coperchio valvole - Valve cover	Acciaio inox AISI 316L - AISI 316L stainless steel
3	Guida valvola - Valve guide	Acciaio inox AISI 316L - AISI 316L stainless steel
4	Molla valvola - Valve spring	Acciaio inox AISI 316L - AISI 316L stainless steel
5	Valvola - Valve	Acciaio inox AISI 316L - AISI 316L stainless steel
6	Sede valvola - Valve seat	Acciaio inox AISI 316L - AISI 316L stainless steel
7	Vite fissaggio pistone - Plunger screw	Acciaio inox AISI 316L - AISI 316L stainless steel
8	Pistone - Plunger	Ceramica integrale - Solid ceramic
9	Camicia - Cylinder	Acciaio inox AISI 316L - AISI 316L stainless steel
10	Anelli di tenuta - Seal rings	NBR
11	Supporto guarnizioni - Packing support	Bronzo Alluminio - Aluminium Bronze
	Elastometri a contatto con il fluido - Wetted elastomers	Buna & EPDM

Tabella prestazioni - Performances chart:

Tipo pompa Pump type	Pressione Pressure			Portata / Volume Potenza / Power								Alesaggio per corsa Bore x stroke mm			
	bar	MPa	p.s.i.												
MSZ 45	80	8	1160	l/min	119	140	114	143	168	143	179	210	172	215	Ø45 X 60
				Hp-kW	25-18	29-21	24-17	30-22	35-26	30-22	37-27	44-32	36-26	45-33	
MSZ 50	80	8	1160	l/min	147	173	141	177	207	177	221	259	212	265	Ø50 X 60
				Hp-kW	31-22	36-26	29-22	37-27	43-32	37-27	46-34	54-40	44-32	55-40	
MSZ 55	80	8	1160	l/min	178	209	171	214	251	214	267	314	256	321	Ø55 X 60
				Hp-kW	37-27	43-32	36-26	44-33	52-38	44-33	56-41	65-48	53-39	67-49	
Velocità rot. ingresso Input speed				g/min r.p.m.	1000		1200		1500		1800				
Rapporto riduttore Gear box ratio				TAU	2,4	2,045	3	2,4	2,045	3	2,4	2,045	3	2,4	
Velocità rot. albero Crankshaft speed				g/min r.p.m.	417	489	400	500	587	500	625	733	600	750	

Portate teoriche con rendimento volumetrico 100% - Volumes are theoretical with 100% volumetric efficiency.

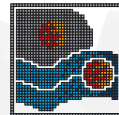

Descrizione - Description

- Pompa volumetrica alternativa a tre pistoni tuffanti orizzontali, realizzata espressamente per applicazioni nell'industria alimentare, chimica, farmaceutica, per osmosi inversa, purificazione, iniezione, processo.
- Parti a contatto con il fluido in acciaio inox. (vedi tabella materiali per dettagli).
- Pistoni in ceramica integrale.
- Presa moto diretta o con riduttore giri.
- Lubrificazione a sbattimento.
- *Triplex positive displacement reciprocating plunger pump, expressly designed for heavy duty applications in the food, chemical and pharmaceutical industries, such a reverse osmosis, purification, injection and processing.*
- *Wetted parts in stainless steel (see material quality chart).*
- *Solid ceramic plungers.*
- *Direct drive or gear box options.*
- *Oil-bath mechanical parts with splash lubrication.*

Specifiche tecniche - Specifications

Velocità minima (Consentite velocità di rotazione inferiori, previo verifica applicazioni) <i>Min. speed (Slower speed allowed after technical approval only)</i>	400 r.p.m.
Battente max. <i>Max. inlet pressure</i>	3 bar (43,5 p.s.i.)
Capacità olio <i>Oil capacity</i>	10 l. (2.6 gal U.S.)
Inlet	n.2 x Ø 66 mm
Outlet	n.2 x 1" 1/4 BSP
Max inlet temp.	60° C (140 °F)
Peso / <i>Weight</i>	245 kg (540 lbs)
Dimensioni / <i>Dimensions</i>	709x604x308 mm

Versione MSN vedi pag.20
MSN version see page 20

Grafico potenza/pressioni - Performance curves based on operating pressure

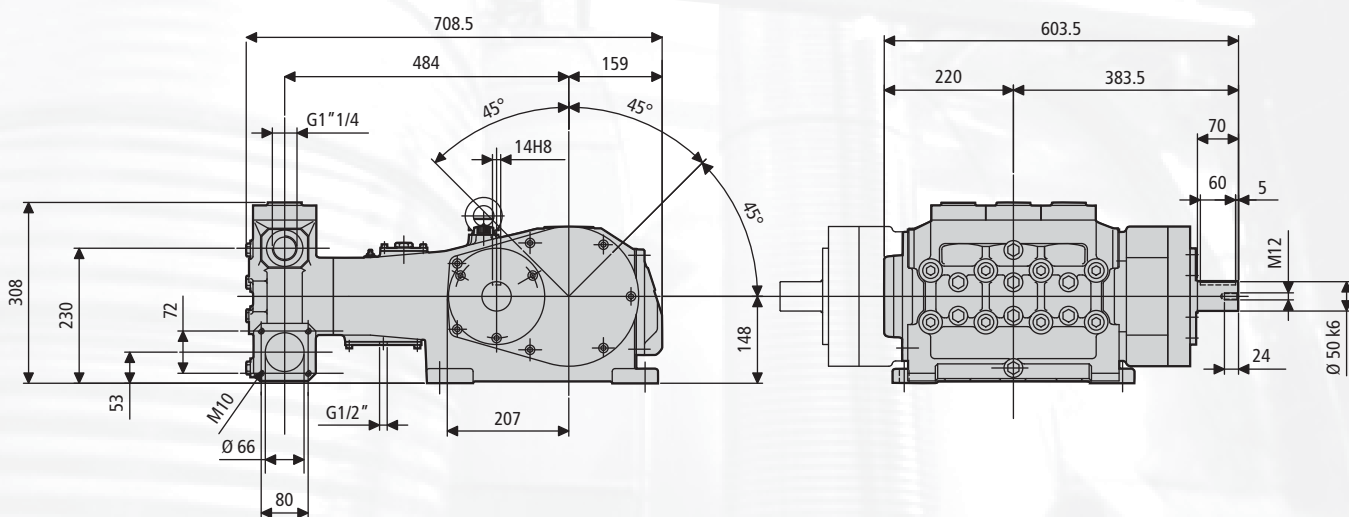
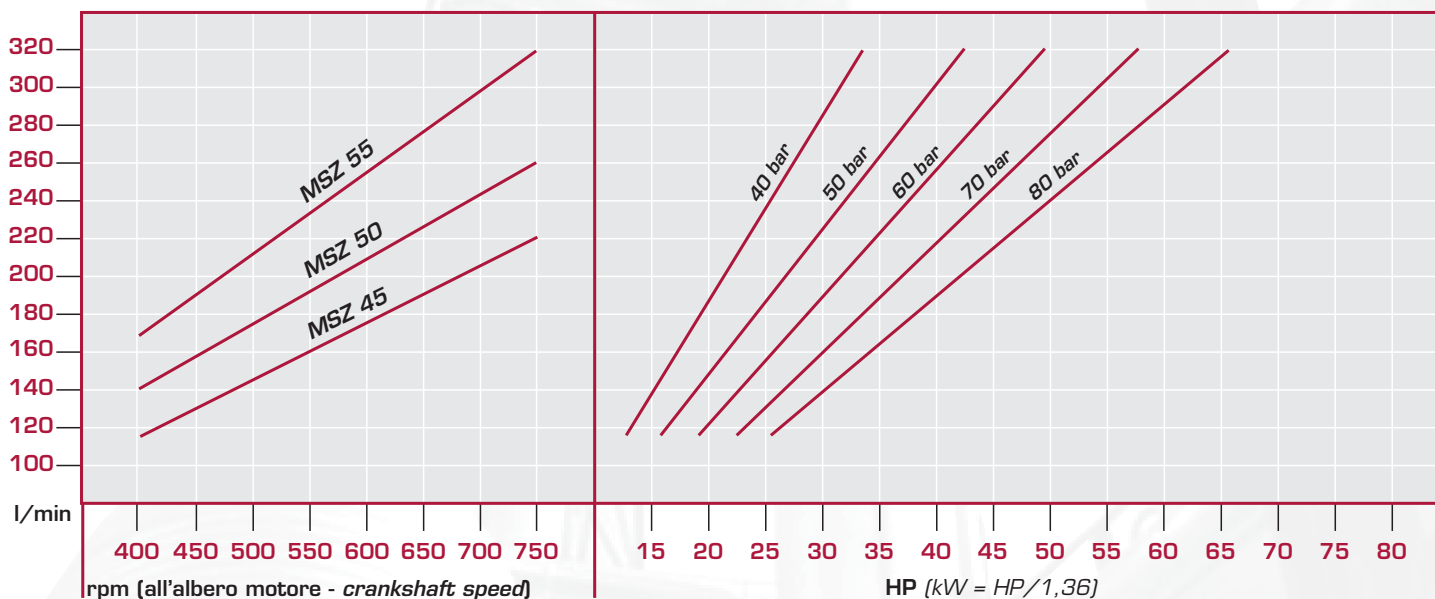

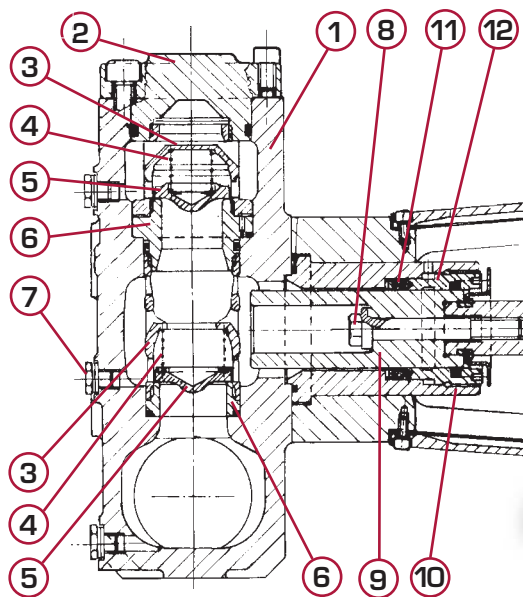
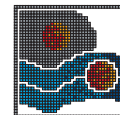

Materiali a contatto con il fluido - Material quality (wetted parts)

Pos.	Descrizione - Description	Materiale - Material
1	Testata - Manifold	Acciaio inox ASTM A890 gr.4 - ASTM A890 gr.4 s.s.
2	Coperchio valvole - Valve cover	Acciaio inox AISI 316L - AISI 316L stainless steel
3	Guida valvola - Valve guide	Acciaio inox AISI 630 - AISI 630 stainless steel
4	Molla valvola - Valve spring	Acciaio inox AISI 316L - AISI 316L stainless steel
5	Valvola - Valve	Acciaio inox AISI 316L - AISI 316L stainless steel
6	Sede valvola - Valve seat	Acciaio inox AISI 316L - AISI 316L stainless steel
7	Tappo di sfiato - Drain plug	Acciaio inox AISI 316L - AISI 316L stainless steel
8	Vite fissaggio pistone - Plunger screw	Acciaio inox AISI 316L - AISI 316L stainless steel
9	Pistone - Plunger	Ceramica integrale - Solid ceramic
10	Camicia - Sleeve	Acciaio inox AISI 316L - AISI 316L stainless steel
11	Anelli di tenuta - Seal rings	NBR
12	Supporto guarnizioni - Gasket holder	Bronzo Alluminio - Aluminium Bronze
	Elastometri a contatto con il fluido - Wetted elastomers	Buna & EPDM

Tabella prestazioni - Performances chart:

Tipo pompa Pump type	Pressione Pressure bar MPa p.s.i.	Portata / Volume Potenza / Power										Alesaggio per corsa Bore x stroke mm	
		l/min	168	180	188	202	216	234	252	269	303		323
LHZ 50	80 8 1160	l/min	168	180	188	202	216	234	252	269	303	323	Ø50 X 90
		Hp-kW	35-26	37-27	39-29	42-31	45-33	49-36	52-39	56-41	63-46	67-49	
LHZ 55	80 8 1160	l/min	204	217	277	244	261	284	305	326	366	391	Ø55 X 90
		Hp-kW	42-31	45-33	47-35	51-37	54-40	59-43	63-47	68-50	76-56	81-60	
LHZ 60	80 8 1160	l/min	242	259	270	291	310	338	363	388	436	466	Ø60 X 90
		Hp-kW	50-37	54-40	56-41	60-44	64-47	70-52	75-56	81-59	91-67	97-71	
Velocità rot. ingresso Input speed		g/min r.p.m.	1000		1200			1500			1800		
Rapporto riduttore Gear box ratio		TAU	3,15	2,95	3,39	3,15	2,95	3,39	3,15	2,95	3,15	2,95	
Velocità rot. albero Crankshaft speed		g/min r.p.m.	317	339	354	381	407	442	476	508	571	610	

Portate teoriche con rendimento volumetrico 100% - Volumes are theoretical with 100% volumetric efficiency.

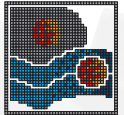

Descrizione - Description

- Pompa volumetrica alternativa a tre pistoni tuffanti orizzontali, realizzata espressamente per applicazioni nell'industria alimentare, chimica, farmaceutica, per osmosi inversa, purificazione, iniezione, processo.
- Parti a contatto con liquido in acciaio inox. (vedi tabella materiali per dettagli).
- Pistoni in ceramica integrale.
- Riduttore giri incorporato.
- Lubrificazione a sbattimento.
- *Triplex positive displacement reciprocating plunger pump, expressly designed for heavy duty applications in the food, chemical and pharmaceutical industries, such a reverse osmosis, purification, injection and processing.*
- *Wetted parts in stainless steel (see material quality chart).*
- *Solid ceramic plungers.*
- *Built-in gear box.*
- *Oil-bath mechanical parts with splash lubrication.*

Specifiche tecniche - Specifications

Velocità minima (Consentite velocità di rotazione inferiori, previo verifica applicazioni) <i>Min. speed (Slower speed allowed after technical approval only)</i>	300 r.p.m.
Battente max. <i>Max. inlet pressure</i>	3 bar (43,5 p.s.i.)
Capacità olio <i>Oil capacity</i>	14 l. (3.7 gal U.S.)
Inlet	n.2 x Ø 80 mm
Outlet	n.2 x Ø 36 mm
Max inlet temp.	60° C (140 °F)
Peso / <i>Weight</i>	365 kg (805 lbs)
Dimensioni / <i>Dimensions</i>	922x656x349 mm

Versione LHN vedi pag.20
LHN version see page 20

Grafico potenza/pressioni - Performance curves based on operating pressure

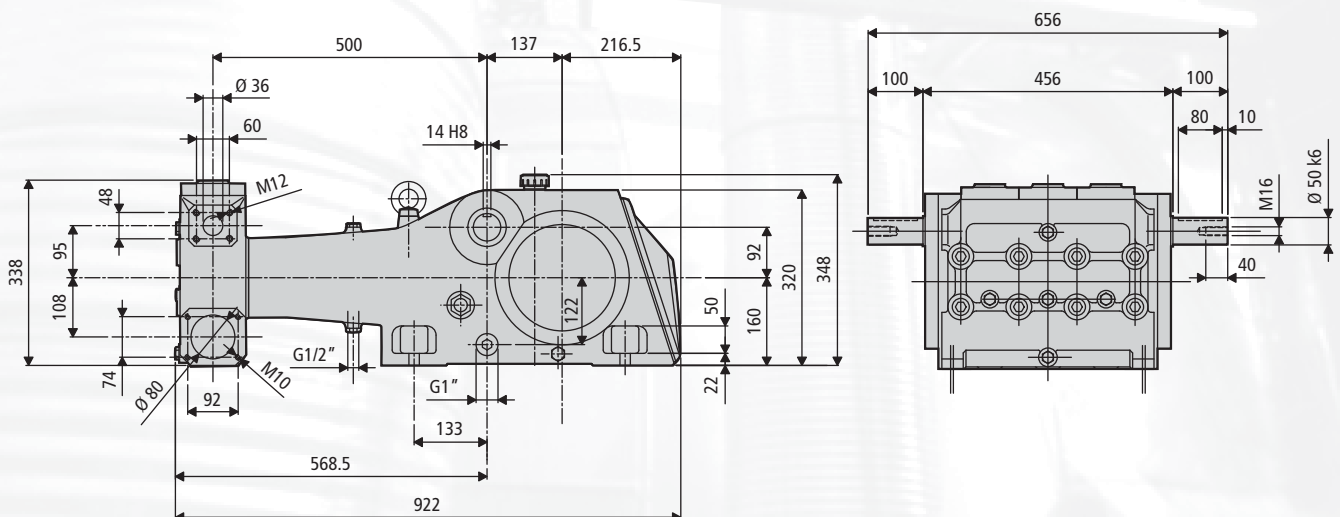
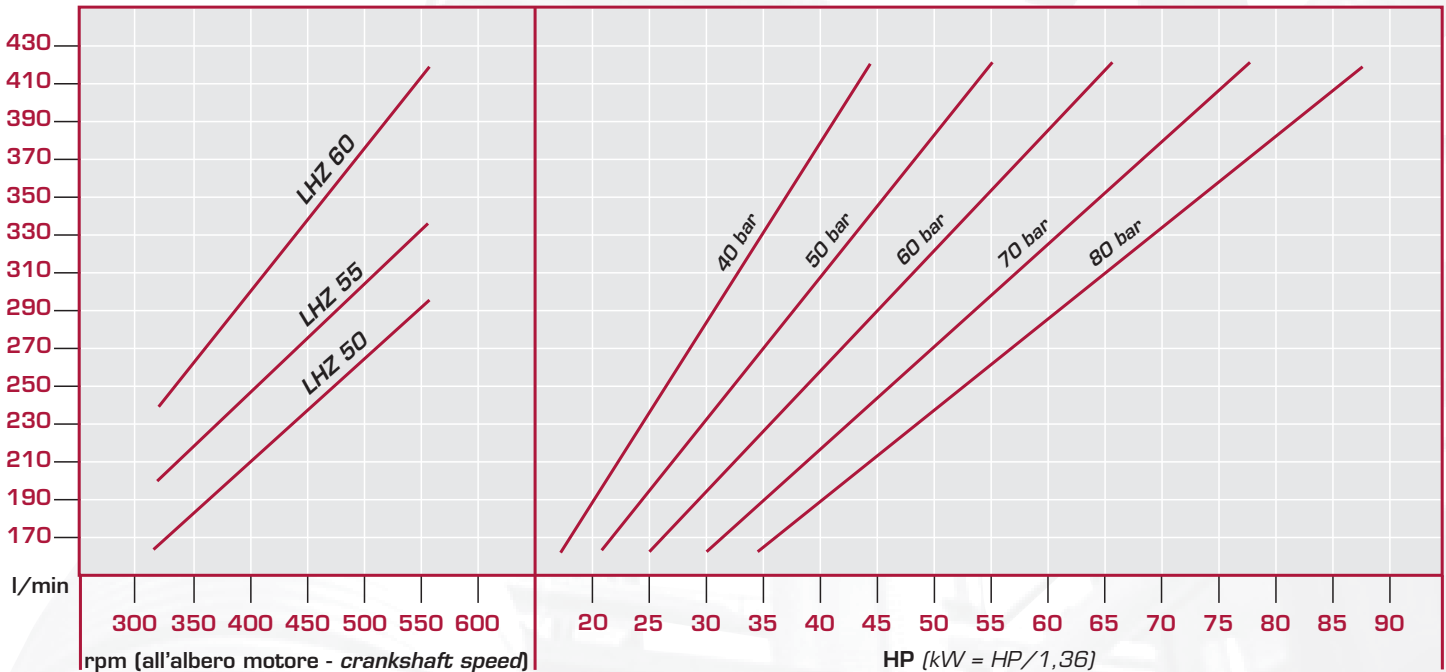

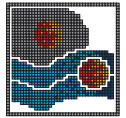

Valvole di massima pressione / Max. pressure setting valves

SX2



Pressione massima / Max. pressure	600 bar - 60 MPa - 8700 p.s.i.
Portata / Volume	190 l/min - 50 GPM
Temp. max acqua / Max. water temp.	60° C - 140° F
Peso / Weight	1,55 kg - 3.41 lbs
Ingresso / Inlet	G 1/2" F
Materiali / Material quality (Parti a contatto con il fluido/ Wetted parts)	AISI 316 /AISI 420

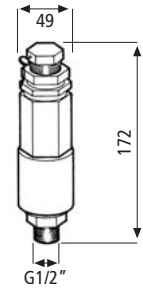

SX3



Pressione massima / Max. pressure	300 bar - 30 MPa - 4350 p.s.i.
Portata / Volume	500 l/min - 132 GPM
Temp. max acqua / Max. water temp.	60° C - 140° F
Peso / Weight	2,55 kg - 5.06 lbs
Ingresso / Inlet	G 3/4" F
Materiali / Material quality (Parti a contatto con il fluido/ Wetted parts)	AISI 316 /AISI 420

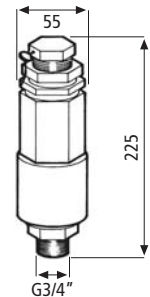

Regolatori di pressione / Regulating valves

SX1



Pressione massima / Max. pressure	250 bar - 25 MPa - 3600 p.s.i.
Portata / Volume	60 l/min - 15.82 GPM
Temp. max acqua / Max. water temp.	85° C - 185° F
Peso / Weight	0,79 kg - 1.75 lbs
Ingresso / Inlet	G 1/2" F
By-pass / By-pass	G 1/2" F
Materiali / Material quality (Parti a contatto con il fluido/ Wetted parts)	AISI 316 L

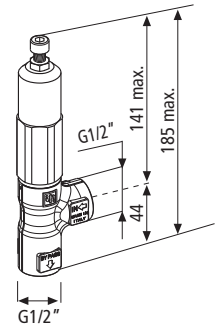

RX1



Pressione massima / Max. pressure	300 bar - 30 MPa - 4350 p.s.i.
Portata / Volume	120 l/min - 32 GPM
Temp. max acqua / Max. water temp.	60° C - 140° F
Peso / Weight	5 kg - 11 lbs
Ingresso / Inlet	G 3/4" F
By-pass / By-pass	G 3/4" F
Materiali / Material quality (Parti a contatto con il fluido/ Wetted parts)	AISI 316 /AISI 420

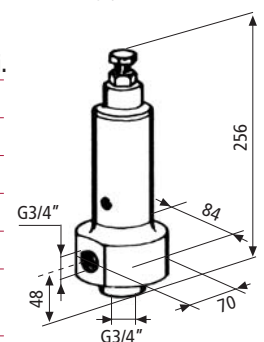

RX3



Pressione massima / Max. pressure	300 bar - 30 MPa - 4350 p.s.i.
Portata / Volume	500 l/min - 132 GPM
Temp. max acqua / Max. water temp.	60° C - 140° F
Peso / Weight	13,5 kg - 30 lbs
Ingresso / Inlet	G 1" 1/4 F
By-pass / By-pass	G 1" 1/4 F
Materiali / Material quality (Parti a contatto con il fluido/ Wetted parts)	AISI 316 /AISI 420

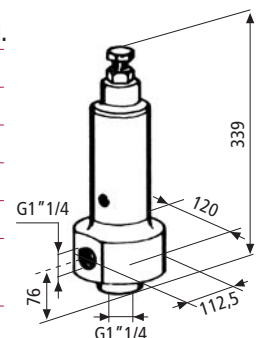

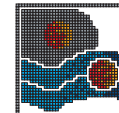

Valvole automatiche / Unloader valves

H253.SS



Pressione massima / <i>Max. pressure</i>	250 bar - 25 MPa - 3600 p.s.i.
Portata / <i>Volume</i>	30 l/min - 7.2 GPM
Temp. max acqua / <i>Max. water temp.</i>	60° C - 140° F
Peso / <i>Weight</i>	1,02 kg - 2.24 lbs
Ingresso / <i>Inlet</i>	G 3/8" F
By-pass / <i>By-pass</i>	G 3/8" M
Materiali / <i>Material quality</i> (Parti a contatto con il fluido/ <i>Wetted parts</i>)	AISI 316L / AISI 420

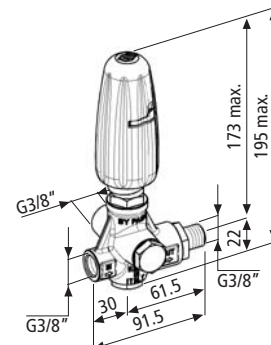

H560



Pressione massima / <i>Max. pressure</i>	500 bar - 50 MPa - 7250 p.s.i.
Portata / <i>Volume</i>	60 l/min - 15.82 GPM
Temp. max acqua / <i>Max. water temp.</i>	60° C - 140° F
Peso / <i>Weight</i>	2,7 kg - 5.9 lbs
Ingresso / <i>Inlet</i>	G 1/2" F
By-pass / <i>By-pass</i>	G 1/2" F - G 1/2" F
Materiali / <i>Material quality</i> (Parti a contatto con il fluido/ <i>Wetted parts</i>)	AISI 420 - Ottone/Brass OT58

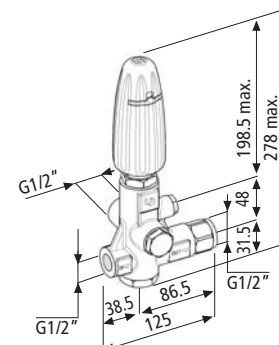

Accumulatori antipulsazioni / Pulsation dampeners

A4X



Pressione massima / <i>Max. pressure</i>	210 bar - 21 MPa - 3050 p.s.i.
Capacità / <i>Volume</i>	0,4 l -
Pressione precarica / <i>Setting pressure</i>	60%
Peso / <i>Weight</i>	2 kg - 4.4 lbs
Ingresso / <i>Inlet</i>	M18 x 1,5F
Materiali (Corpo / Membrana)	AISI 316 / Gomma nitrilica
<i>Material quality (Shell / Bladder)</i>	AISI 316 / Nitrile rubber

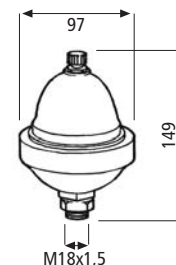

A7X



Pressione massima / <i>Max. pressure</i>	150 bar - 15 MPa - 2150 p.s.i.
Capacità / <i>Volume</i>	0,7 l
Pressione precarica / <i>Setting pressure</i>	60%
Peso / <i>Weight</i>	3,9 kg - 8.6 lbs
Ingresso / <i>Inlet</i>	3/4" G
Materiali (Corpo / Membrana)	AISI 316 / Gomma nitrilica
<i>Material quality (Shell / Bladder)</i>	AISI 316 / Nitrile rubber

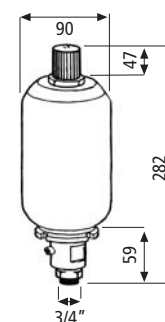

A15X



Pressione massima / <i>Max. pressure</i>	150 bar - 15 MPa - 2150 p.s.i.
Capacità / <i>Volume</i>	1,5 l
Pressione precarica / <i>Setting pressure</i>	60%
Peso / <i>Weight</i>	7,1 kg - 15.6 lbs
Ingresso / <i>Inlet</i>	3/4" G
Materiali (Corpo / Membrana)	AISI 316 / Gomma nitrilica
<i>Material quality (Shell / Bladder)</i>	AISI 316 / Nitrile rubber

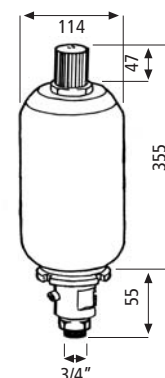

Giunti / Flexible couplings

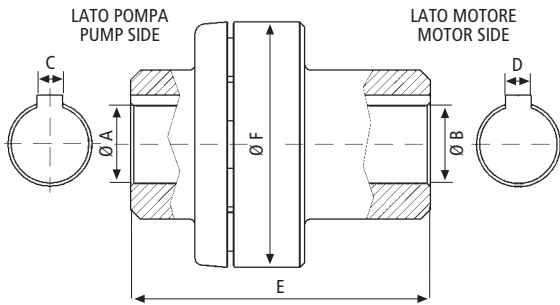

Pump series	Codice Code	A Ø mm	B Ø mm	C mm	D mm	E mm	F Ø mm	Motore Motor
63.SS	ZG044	24	28	8	8	102	76	MEC 100-112
63.SS	ZG070	24	24	8	8	93	76	MEC 90
63.SS	ZG080	24	19	8	6	81	57,5	MEC 80
47.SS 66.SS	ZG132	24	38	8	10	121*	102	MEC 132
47.SS 66.SS	ZG151	24	28	8	8	105	76	MEC 100-112
66.SS	ZG066	24	42	8	12	157	124	MEC 160
70.SS	ZG70160	30	42	8	12	194	102	MEC 160
70.SS	ZG70180	30	48	8	14	194	102	MEC 180

* Con distanziale / With spacer

Flange / Flange

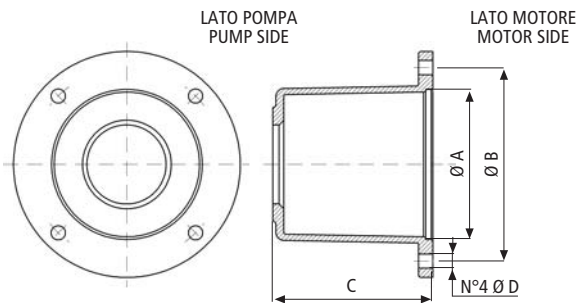

Pump series	Codice Code	A Ø mm	B Ø mm	C mm	D Ø mm	Motore Motor
63.SS	ZF044	110	130 115	110	9	MEC 100-112/B3-B14
63.SS	ZF070	95	130 115	101	9	MEC 90/B3-B14
63.SS	ZF080	80	75 100	92,5	7	MEC 80
47.SS 66.SS	ZF132	130	165	127	11	MEC 132/B3-B14
47.SS 66.SS	ZF151	110	130	110	9	MEC 100-112/B3-B14

Materiali opzionali / Optional materials



70.SS / 71.SS - Testata /Manifold : DUPLEX F51 Stainless steel

MSN - MSB/ LHN - Versioni fino a 300 bar / Versions up to 300 bar



Pos.	Descrizione Description	MSZ LHZ	MSN MSB LHN
6	Molla valvola Valve spring	AISI 316 L	AISI 302
5	Valvola Valve	AISI 316 L	AISI 431
4	Sede valvola Valve seat	AISI 316 L	AISI 431

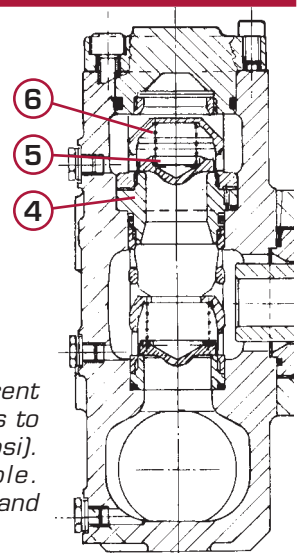

Le versioni N e B delle pompe MS/LH dispongono di valvole realizzate in inox ad alta resistenza per poter raggiungere pressioni operative fino a 300 bar. Disponibili nuove testate speciali per applicazioni dedicate. Contattare i ns. uffici vendita per specifiche e disponibilità.

MS/LH N and B versions feature different stainless steel quality of valve components to allow operation up to 300 bar (4350 psi). Block style manifolds also available. Check with Sales Dept. for specifications and availability.



*I dati tecnici sono indicativi e possono essere modificati senza preavviso.
Technical data are indicatives and subject to changes without notice.*

*Graphic lay-out: Gi&Vi - Reggio Emilia
Photolithography: La Fotolito Poviglio (R.E.)
Printed by: Arti Grafiche de Pietri Castelnovo di Sotto (R.E.)*



INTERPUMP GROUP S.p.A.
Via E. Fermi, 25 - 42049 S. Ilario d'Enza (RE) - Italy
Tel. +39 0522 904311 - Fax +39 0522 904444
www.interpumpgroup.it - www.pratissolipompe.com